

References and Notes

- (1) Trost, B. M.; Bogdanowicz, M. J. *J. Am. Chem. Soc.* **1973**, *95*, 5311. Trost, B. M.; Kurozumi, S. *Tetrahedron Lett.* **1974**, 1929. Trost, B. M.; Keeley, D. E. *J. Am. Chem. Soc.* **1976**, *98*, 248. Trost, B. M.; Nishimura, Y.; Yamamoto, K. *Ibid.* **1979**, *101*, 1328.
- (2) Jung, M. E.; Hudspeth, J. P. *J. Am. Chem. Soc.* **1977**, *99*, 5508. Hayakawa, Y.; Yokoyama, K.; Noyori, R. *Ibid.* **1978**, *100*, 1791. Hiyama, T.; Shinoda, M.; Nozaki, H. *Ibid.* **1979**, *101*, 1599. Marfat, A.; Helquist, P. *Tetrahedron Lett.* **1978**, 4217. Hiyama, T.; Shinoda, M.; Nozaki, H. *Ibid.* **1978**, 771. Corey, E. J.; Boger, D. L. *Ibid.* **1978**, 13. Jacobson, R. M.; Abbaspour, A.; Lahm, G. P. *J. Org. Chem.* **1978**, *43*, 4650. Jacobson, R. M.; Lahm, G. P. *Ibid.* **1979**, *44*, 462. Bellassoued, M.; Frangin, Y.; Gaudemar, M. *Synthesis* **1978**, 151. Ito, Y.; Nakayama, K.; Yonezawa, K.; Saegusa, T. *J. Org. Chem.* **1974**, *39*, 3273.
- (3) For reviews see Trost, B. M. *Tetrahedron* **1977**, *33*, 2615; *Pure Appl. Chem.*, **1979**, *51*, 787.
- (4) Cf. Carlson, R. M. *Tetrahedron Lett.* **1978**, 111. Also see Sarkar, T. K.; Andersen, N. H. *Ibid.* **1978**, 3513.
- (5) Noyori, R.; Kumagai, Y.; Umeda, I.; Takaya, H. *J. Am. Chem. Soc.* **1979**, *94*, 4018.
- (6) Binger, P. *Synthesis* **1973**, 427.
- (7) Noyori, R.; Odagi, T.; Takaya, H. *J. Am. Chem. Soc.* **1970**, *92*, 5780.
- (8) A 12 ft \times $\frac{1}{4}$ in. 15% Carbowax on Chromosorb W column was employed at 110 °C with a flow rate of 7 mL/min for this analysis.
- (9) For reviews see: (a) Dowd, P. *Acc. Chem. Res.* **1972**, *5*, 242. (b) Berson, J. A.; *Ibid.* **1978**, *11*, 446.
- (10) Noyori, R.; Hayashi, N.; Kato, M. *J. Am. Chem. Soc.* **1971**, *93*, 4948.
- (11) Binger, P.; Schuchardt, U. *Angew. Chem., Int. Ed. Engl.* **1977**, *16*, 249.
- (12) For reaction of trimethylenemethaneiron tricarbonyl, see: Day, A. C.; Powell, J. T. *Chem. Commun.* **1968**, 1241. Ehrlich, K.; Emerson, G. F. *J. Am. Chem. Soc.* **1972**, *94*, 2464.
- (13) Takahashi, S.; Naganawa, H.; Iinuma, H.; Takita, T.; Maeda, K.; Umezawa, H. *Tetrahedron Lett.* **1971**, 1955.

Barry M. Trost,* Dominic M. T. Chan

Samuel M. McElvain Laboratories of Organic Chemistry
Department of Chemistry, University of Wisconsin—Madison
Madison, Wisconsin 53706

Received April 23, 1979

2-Acetoxyethyl-3-allyltrimethylsilane
and Palladium(0): A Source of
Trimethylenemethane-Palladium Complex?

Sir:

In the previous paper,¹ we reported the cycloaddition of 2-acetoxyethyl-3-allyltrimethylsilane to electron-deficient olefins catalyzed by palladium(0) with formation of methylenecyclopentanes (eq 1). This rather surprising cycloaddition

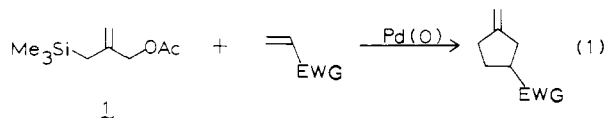

led us to propose the pathway in eq 2 as a working hypothesis. In this paper, we present evidence in support of this hypothesis—thus suggesting that **1** may be a valuable precursor to trimethylenemethane-metal complexes.^{2,3}

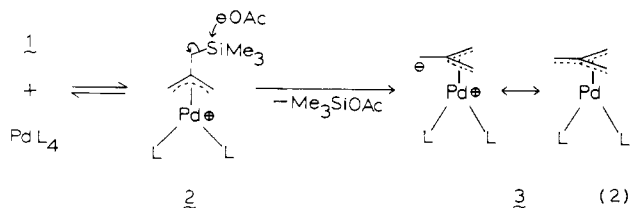

The initial formation of **2** is suggested by the reaction of **1** with dimethyl sodiomalonate to give the alkylated product **4**.⁴ On the other hand, reaction with the anion of dimedone gave only the product of alkylation and desilylation, **5**. Interestingly, the anion of bis(benzenesulfonyl)methane leads to a mixture of **6** and **7**.

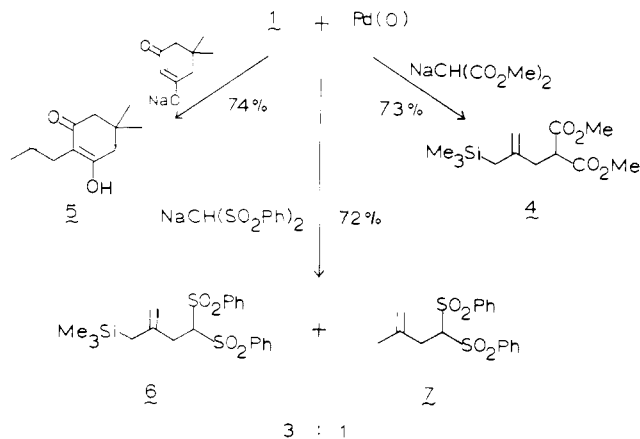

The formation of desilylated products does not arise from protodesilylation of the product or **1** under the reaction conditions as demonstrated by control experiments. Thus, some intermediate must be undergoing desilylation to lead to **5** and **7**. Apparently, if a nucleophile is kinetically slow in attacking **2**, **2** lives long enough to suffer desilylation and generation of **3**. The latter is protonated by the excess dimedone or bis-(benzenesulfonyl)methane or their alkylated products to give **8** which then reacts with starting nucleophile to give the desily-

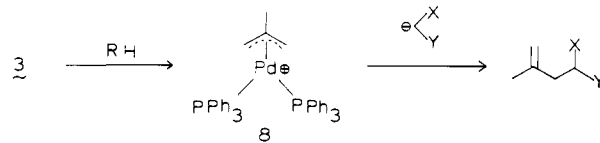

lated product. Thus, the order of reactivity of the three nucleophiles toward **2** is malonate > bis(benzenesulfonyl)methane anion > dimedone anion—accounting for the straight alkylation with malonate, a competition of alkylation and desilylation with the sulfone system, and complete desilylation with dimedone.

To test this idea, **1** was reacted with acetophenone in the presence of the Pd(0) catalyst. Ketones do not react with allylic acetates in the presence of catalyst without a base.⁴ The fact that desilylated-alkylated product **9** was obtained indicates

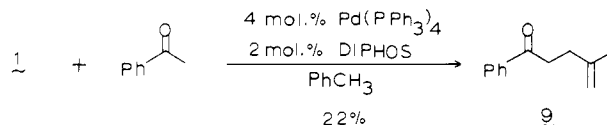

that a base formed to generate the enolate of acetophenone and **8**.⁵ This observation strongly implicates **3** as that base.

That the cycloaddition intermediate is a nucleophile and not an electrophile is indicated by its reaction with electron-deficient olefins and its failure to react with electron-rich ones. The reaction can be rationalized as shown in eq 3.⁶ The partial loss of stereochemistry, i.e., methyl (*Z*)-cinnamate (*Z*:*E*, 10:1) gives a 1:1.3 ratio of *E* and *Z* isomers of methyl 2-phenyl-4-methylenecyclopentylcarboxylate, indicates equilibration of

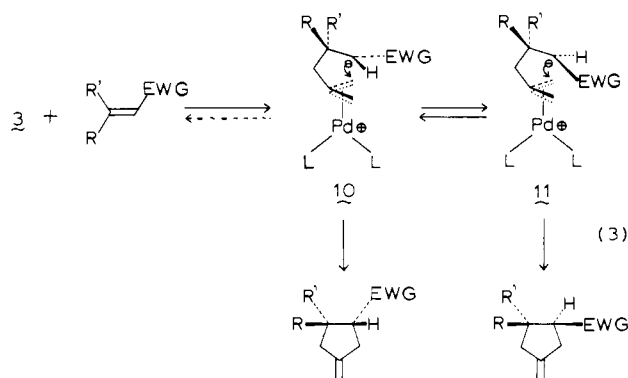

10 and **11** can compete with cyclization. In this case, starting olefin is not observed to isomerize under the reaction conditions. The ring closure of **10** and **11** is postulated in analogy to normal nucleophilic attack on π -allylpalladium cationic complexes.⁷ Usually, simple enolates such as those from ketones and esters do not attack such complexes in good yield.^{4,8} Presumably the intramolecularity of the cyclization reaction allows domination by the desired alkylation over the competing decomposition reactions observed in the intermolecular cases.

Further evidence of the behavior of **3** as a zwitterionic type species stems from the competing cycloaddition to give **12** and desilylative alkylation to give **13** when benzylideneacetone is employed as a trap (eq 4). Thus, with a trap that possesses an

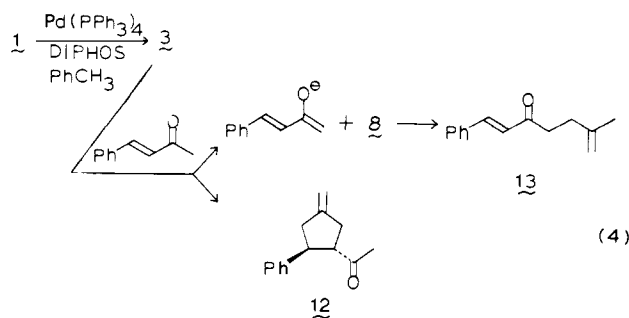

electrophilic unit and acidic protons, both the nucleophilicity and basicity of **3** is observed. Performing the reaction in refluxing THF leads almost exclusively to **12** which indicates that the nucleophilicity of **3** is enhanced at the expense of its basicity in this solvent.

The above results clearly show that the reaction of **1** and Pd(0) is initiated by ionization of acetate and that desilylation occurs before reaction with electron deficient olefins and some nucleophiles. Only a complex such as **3** appears compatible with these experimental observations.⁹ Furthermore, this complex has the behavior of a zwitterion. It is interesting to contrast the complex with the free ligand which behaves more like a diradical.¹⁰ These results can be contrasted to that of Binger and Schuchardt^{3c} who claim to have generated this complex from methylenecyclopropane and a Pd(0) species generated in situ. While they report trapping with electron-deficient olefins in unstated yields and with *E-Z* isomerization, they also report trapping with norbornene—a reaction that we do not observe. In such a case, it is difficult to ascertain whether direct reaction of the highly reactive methylenecyclopropane with the olefins catalyzed by palladium occurred or whether opening to trimethylenemethane-palladium preceded reaction. By analogy to the nickel catalyzed reaction of methylenecyclopropane,¹¹ it appears that, at least for the norbornene case, the former appears more likely. Such an ambiguity does not exist for **1**. Thus, it may serve as a general entry into trimethylenemethane-transition metal complexes without the annoying self-oligomerization and direct condensation of methylenecyclopropane.³

Acknowledgment. We thank the National Science Foundation for their generous support of our programs. We also thank Englehardt Industries and Mathey-Bishop for their generous gifts of palladium salts.

References and Notes

- (1) Trost, B. M.; Chan, D. *J. Am. Chem. Soc.*, preceding paper in this issue.
- (2) For routes to stable trimethylenemethane complexes see: Emerson, G. F.; Ehrlich, K.; Giering, W. P.; Lauterbur, P. C. *J. Am. Chem. Soc.* **1966**, *88*, 3172. Ehrlich, K.; Emerson, G. F. *Ibid.* **1972**, *94*, 2464. Kerber, R. C.; Ehnolt, D. J. *Ibid.* **1973**, *95*, 2927. Day, A. C.; Powell, J. T. *Chem. Commun.* **1968**, 1241. Ehrlich, K.; Emerson, G. F. *Ibid.* **1969**, 59. Noyori, R.; Nishimura, T.; Takaya, H. *Ibid.* **1969**, 89. Nesmeyanov, A. N.; Astakhova, I. S.; Zol'nikova, G. P.; Kritskaya, I. I.; Struchkov, Y. T. *Ibid.* **1970**, 85. Ward, J. S.; Pettit, R. *Ibid.* **1970**, 1419. Kagan, J.; Lin, W.-L.; Cohen, S. M.;

Schwartz, R. N. *J. Organomet. Chem.* **1975**, *90*, 67.

- (3) For generation and purported generation of such complexes as transient intermediates see: (a) Noyori, R.; Yamakawa, M.; Takaya, H. *Tetrahedron Lett.* **1978**, 4823 and earlier references. (b) Binger, P. *Synthesis* **1973**, 427. (c) Binger, P.; Schuchardt, U. *Angew. Chem., Int. Ed. Engl.* **1977**, *16*, 249.
- (4) For reviews see Trost, B. M. *Tetrahedron*, **1977**, *33*, 2615; *Pure Appl. Chem.*, in press.
- (5) Generally, simple enolates react with π -allylpalladium cationic complexes in a stoichiometric reaction to give mainly decomposition. Recent work with the enol silyl ether of acetophenone as an enolate precursor and allyl acetate shows that C-alkylation occurs under palladium catalysis (E. Keinan, unpublished observations in these laboratories).
- (6) This scheme represents a simplified version. Prior coordination of the electron-deficient olefin to palladium(0) may occur (Ozawa, F.; Ito, T.; Nakamura, Y.; Yamamoto, A. *J. Organomet. Chem.* **1979**, *168*, 375). Furthermore, an oxa- π -allyl- π -allyl sandwich complex may be the initial intermediate in lieu of **10** and **11** (for oxa- π -allyl complexes see Ito, Y.; Aoyama, H.; Hirao, T.; Mochizuki, A.; Saegusa, T. *J. Am. Chem. Soc.* **1979**, *101*, 494).
- (7) Trost, B. M.; Verhoeven, T. R. *J. Org. Chem.* **1976**, *41*, 3215. Trost, B. M.; Weber, L.; Strege, P. E.; Fullerton, T. J. *J. Am. Chem. Soc.* **1978**, *100*, 3416. Trost, B. M.; Verhoeven, T. R. *Ibid.* **1978**, *100*, 3435.
- (8) Trost, B. M.; Weber, L.; Strege, P. E.; Fullerton, T. J.; Dietsche, T. J. *J. Am. Chem. Soc.* **1978**, *100*, 3426.
- (9) It should be noted that invoking a trimethylenemethane-palladium(0) complex does not make a statement regarding the symmetry of the complex. As represented in **3**, the complex has C_6 symmetry. If the palladium rapidly migrates among the possible π -allyl units or effectively sets below the central carbon, then the complex would have (effective) C_{3v} symmetry. The nickel⁹ and iron² complexes apparently have the latter symmetry. At this time, we do not differentiate between these possibilities.
- (10) Dowd, P. *Acc. Chem. Res.* **1972**, *5*, 252. Berson, J. A. *Ibid.* **1978**, *11*, 446.
- (11) Noyori, R.; Kumagai, Y.; Umeda, I.; Takaya, H. *J. Am. Chem. Soc.* **1972**, *94*, 4018. Noyori, R.; Ishigami, T.; Hayashi, N.; Takaya, H.; *J. Am. Chem. Soc.* **1973**, *95*, 1674. For evidence that such a reaction can go through trimethylenemethane-metal complexes, see ref 2 and 3.

Barry M. Trost,* Dominic M. T. Chan

Samuel M. McElvain Laboratories of Organic Chemistry
Department of Chemistry, University of Wisconsin—Madison
Madison, Wisconsin 53706

Received April 23, 1979

Reactions of Benzaldehyde with Trialkylsilyl Metal Carbonyl Complexes

Sir:

Our interest in new methodology for the formation of metal-carbon bonds¹ and the chemistry of the various oxidation states of metal-bound carbon² has led us to investigate the use of trialkylsilyl metal carbonyl complexes as reagents for organometallic synthesis. In this communication, we report that the metal silanes $(CO)_5MnSi(CH_3)_3$ (**1**),³ $(CO)_4Fe[Si(CH_3)_3]_2$ (**2**),⁴ and $(CO)_4FeSi(CH_3)_2CH_2CH_2Si(CH_3)_2$ (**3**)⁵ undergo reactions with benzaldehyde which result, under appropriate conditions, in the formation of α -silyloxybenzyl- and benzylidene-derived ligands.

The reaction of **1** with benzaldehyde was carried out at 5 °C in the absence of solvent. From an equimolar mixture of reactants, the insertion product **4** was formed in 65% yield after 2 weeks (eq 1).^{6a} Employing a twofold excess of benzaldehyde

